

REV	DESCRIPTION	DATE
A	CORRECTED RACK MOUNT BRACKET DETAIL	10/11/01

NOTES

MATERIAL TOP & BOTTOM 0.062" STEEL, SIDES, FRONT, REAR & HORIZONTAL SUPPORTS 0.125" ALUMINUM, DIMENSIONS ARE TAKEN WITH THE PAINTED SURFACE

FINISH TOP, BOTTOM & SIDE PANELS, TEXTURED BLACK, FRONT/REAR PANELS ON SMOOTH BLACK, ONE CONTEMPRA GRAY (RAL 7032), ALL POWDER PAINT,

FRONT VIEW

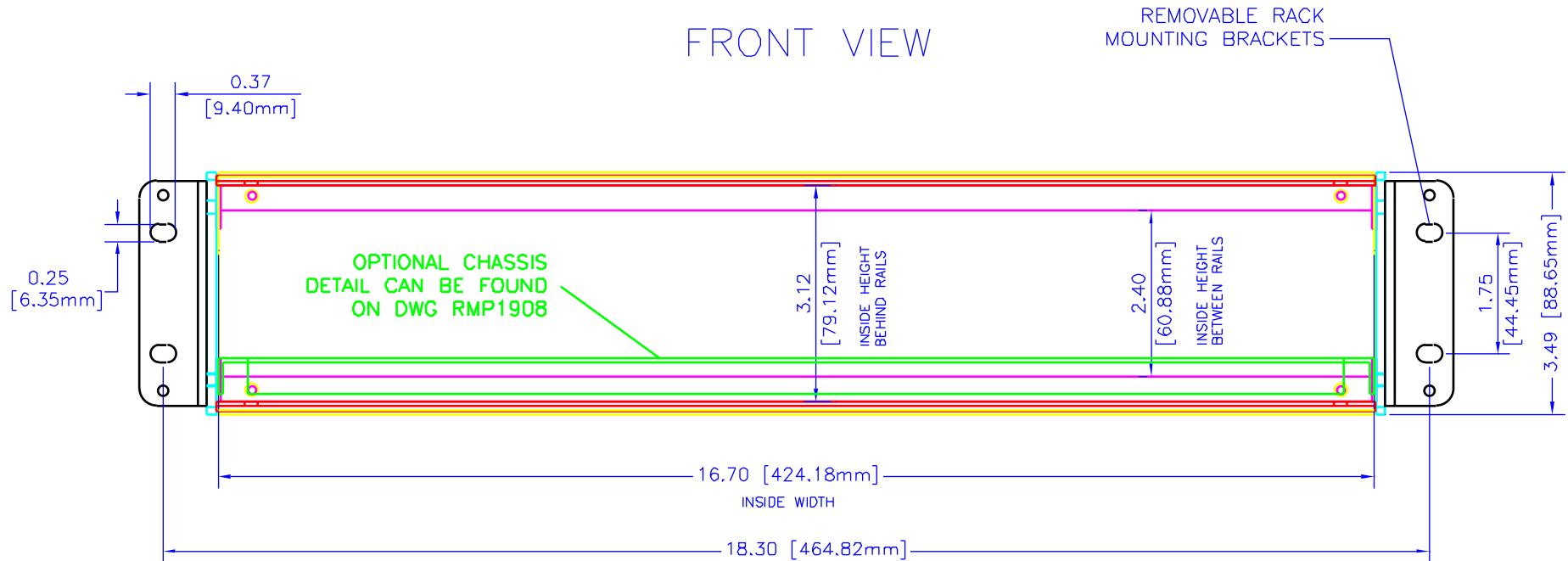

UNLESS OTHERWISE SPECIFIED
DIMENSIONS ARE IN INCHES

F +/- .1
XX +/- .02
XXX +/- .015
ZITE +/- .005
ANGLES +/- .5 DEG.



**HAMMOND
MANUFACTURING**

WEB: WWW.HAMMONDMFG.COM

TITLE HAMMOND RMCS SERIES
RACK ENCLOSURE

DRAWN BY MJM DATE 09/17/01

SCALE PAGE 1 OF 3

PART NUMBER
RMCS19038

SIDE VIEW

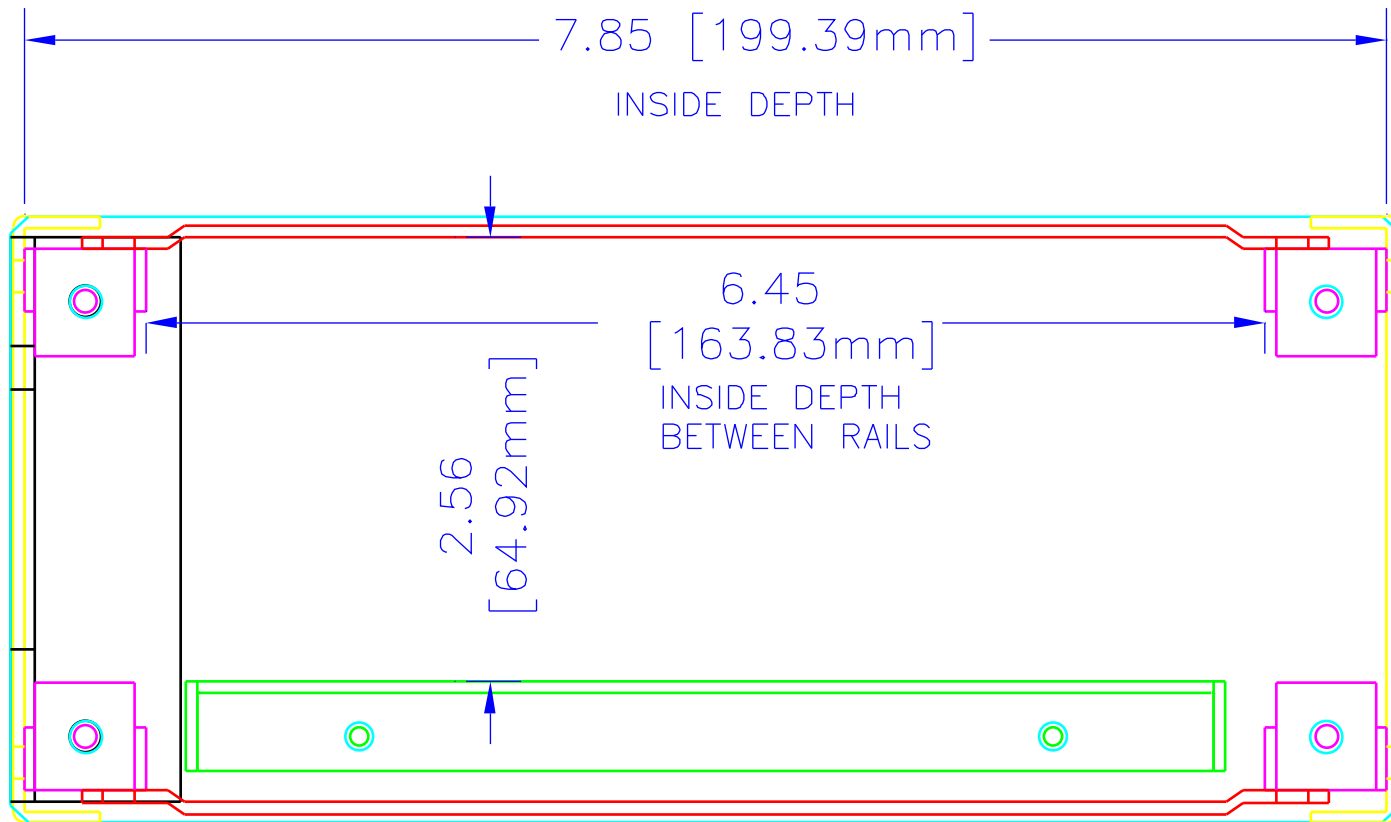

UNLESS OTHERWISE SPECIFIED DIMENSIONS ARE IN INCHES	
X	+/- .1
XX	+/- .02
XXX	+/- .015
CUTS	+/- .005
ANGLES	+/- 5 DEC

NOTICE
HAMILTON CLAIMS PROPRIETARY RIGHTS TO
THE MATERIAL ON THIS DRAWING. IT IS
INTENDED TO BE USED AS A REFERENCE FOR
DISCREPANCY INFORMATION ONLY. THIS
INFORMATION MAY NOT BE USED TO
REPRODUCE, REPLICATE, WITHOUT WRITTEN
PERMISSION FROM HAMILTON MANUFACTURING.



**HAMMOND
MANUFACTURING**

WEB: WWW.HAMMONDMFG.COM

TITLE
HAMMOND RMCS SERIES
RACK ENCLOSURE

DRAWN BY	MJM	DATE	09/17/01
SCALE		PAGE	2 OF 3

PART NUMBER
RMCS19038

TOP VIEW

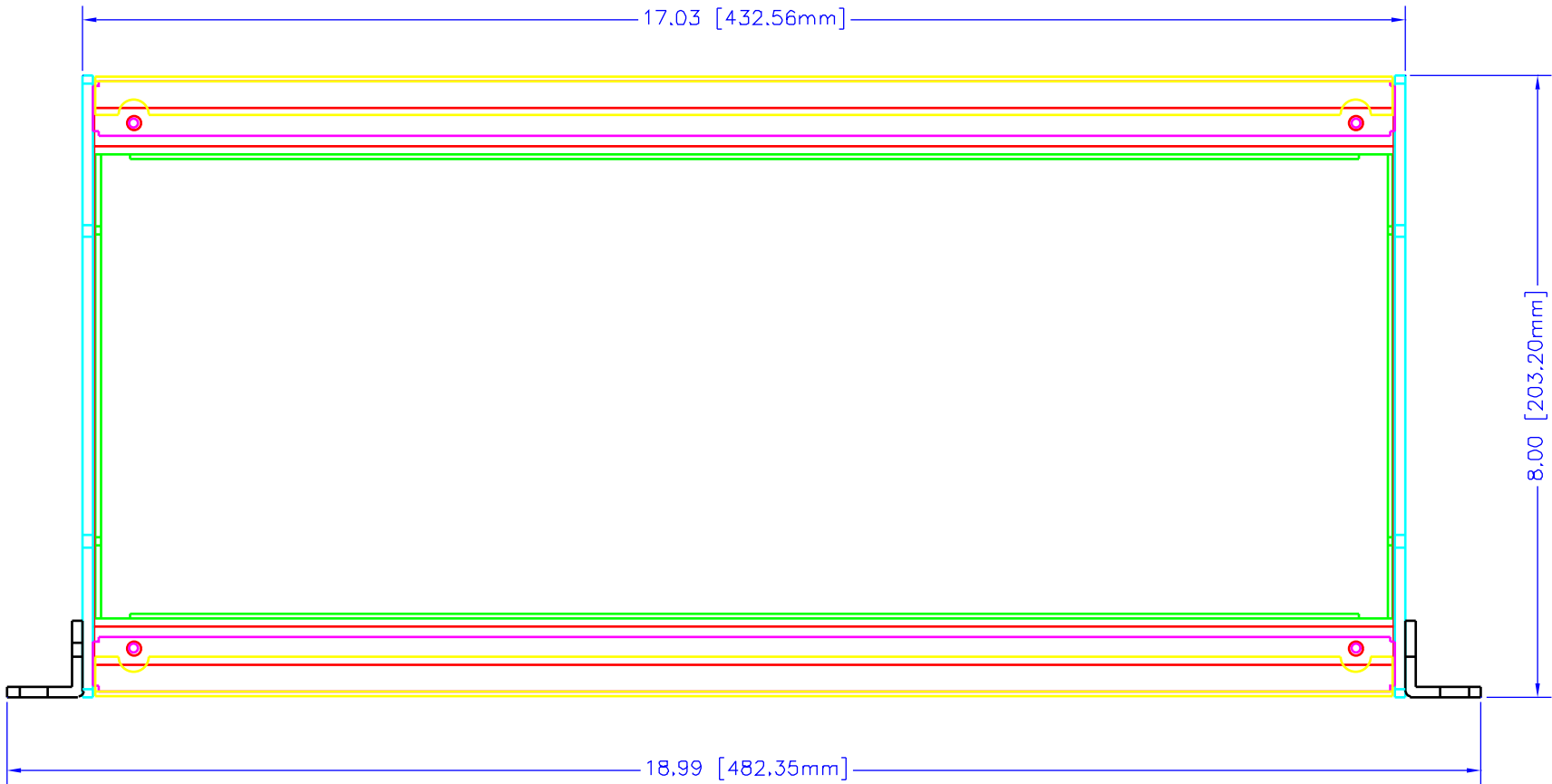

UNLESS OTHERWISE SPECIFIED DIMENSIONS ARE IN INCHES	
X	+/- .1
XX	+/- .02
XXX	+/- .015
CUTS	+/- .002
ANGLES	+/- 5 DEC

NOTICE
 HAMMOND CLAIMS PROPRIETARY RIGHTS TO
 THE MATERIAL ON THIS DRAWING. IT IS
 INTENDED TO BE USED AS A REFERENCE FOR
 DISCREPANCY INFORMATION ONLY. THIS
 INFORMATION MAY NOT BE USED TO
 MANUFACTURE, REPRODUCE, WITHOUT WRITTEN
 PERMISSION FROM HAMMOND MANUFACTURING.



**HAMMOND
 MANUFACTURING**

WEB: WWW.HAMMONDMFG.COM

TITLE
**HAMMOND RMCS SERIES
 RACK ENCLOSURE**

DRAWN BY	MJM	DATE	09/17/01
SCALE		PAGE	3 OF 3

PART NUMBER
RMCS19038